

SIEMENS

UMTS

Opening Up a World of Opportunities



UMTS

Opening Up a World of Opportunities

Mobile telephony plays an ever increasing role in the telecommunication business.

Different markets such as computer, audio, video and telecommunication are converging. Users of data and multimedia telecommunication services expect and demand that these same services are also available to them while they are on the move. New business opportunities and more competition for network operators are developing as a result of these market changes.

UMTS is the key enabler to bring multimedia services into the mobile environment.

The GSM Springboard to the Future

To pave the way for this promising future, a smooth evolution from existing second generation systems to third generation systems has to be ensured. Due to the fact that GSM is the most successful digital system with 369 members in 137 countries, its evolution is one of the most important aspects of developments in the telecommunications environment. Industry experts agree that those businesses best able to take advantage of 3rd generation mobile systems are the cellular system operators, most of whom use GSM as the best accepted digital standard today.

Since UMTS, the global broadband 3rd generation mobile communication standard evolves from existing GSM technology, today's GSM operators are well-positioned to become the most significant players in the third generation mobile market.

Siemens' Evolutionary Path

Siemens' vision of the future of mobile telecommunications focuses on the evolution and development of next generation mobile networks and mobile applications.

Highlights

- 3G/UMTS is the platform for personal mobile communication at the beginning of the next millennium.
- 3G user needs arise from current trends in the telecommunication, computing and entertainment industries.
- 3G must therefore provide full flexibility to cope with future users' needs determined by a high increase in user density, airtime per user and net information throughput per user.
- 3G decisions were made on the UMTS air interface. UTRA (Universal Terrestrial Radio Access) comprises the opportunity to overcome 2G limitations by deploying seamless user services via two modes (FDD and TDD). Both modes target overlapping applications, obtain additional spectrum through enhanced efficiency and are accepted by globally acting operators and vendors.
- 3G by Siemens offers one-stop-shopping for 3G networks, terminals and applications.

A Booming Market

In the next decade, a tremendous growth of mobile subscribers is expected worldwide.

The UMTS market is developing out of today's 2G mobile, fixed and data markets. It is essential, therefore, to start 3G activities today. UMTS both builds on and enhances the capability of today's telecommunication technologies by providing users with greater capacity, data functionality and a broader range of services. This is achieved using an innovative radio access scheme and an improved core network. Siemens fully supports the UMTS standard and, together with the UMTS Forum, believes that third generation broadband telecommunication systems will take users into the future information society. Broadband mobile telecommunications will deliver voice, data and multimedia services, as required, directly to the end-user in

any environment. In line with the dramatic increase in the number of GSM subscribers, a similar exponential growth in GSM data subscribers is expected. Today, less than 3% of GSM subscribers use data services. In 2005, that figure is expected to account for 15% to 20% of GSM subscribers.

Driven by the Internet

The tremendous growth of the Internet is a key driving force of this increase in market demand. Another one is the increased data transmission opportunities of new GSM Phase 2+ data services.

Greater Demand for Mobile Data Services

Together with related developments in handheld computing, new data services, such as GPRS, EDGE and HSCSD make mass market mobile data services possible. The third generation (UMTS) will then enhance circuit and packet mode functionalities through better performance and availability in all environments.

Not only the growth in the number of GSM mobile subscribers, but also increasing numbers of subscribers using data services, will lead to the expected growth in data traffic. These assumptions correlate with developments in data volume for fixed networks: already today the share of data traffic is 40%. Similar trends are forecast for mobile communication if market developments result in competitive pricing of equipment and usage.

World mobile subscribers

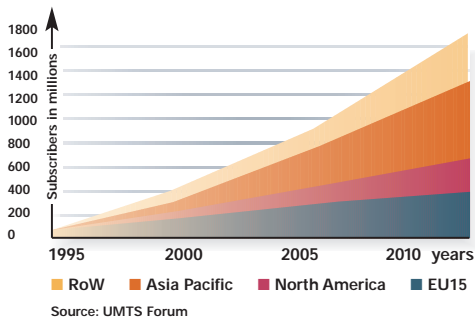

Mobile data market towards mass market

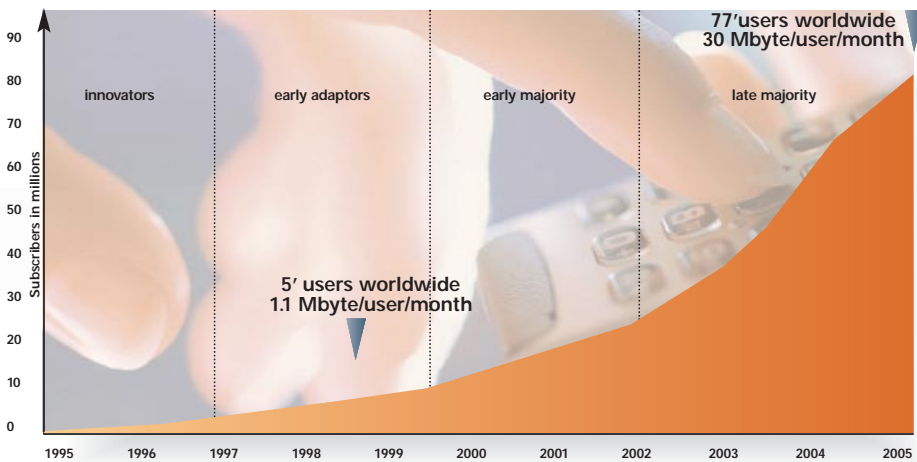

- Growth in mobile data is expected to be 70% p.a. in the next 5 years
- Multimedia will account for up to 60% of total mobile traffic in 2005.

Source: Merrill Lynch, UMTS MAG

Converging Applications

Demand UMTS

Innovative applications are the business drivers in an exploding mobile market.

Voice, data, and IP applications are increasingly sought after by mobile customers, and just as important, they serve as a means to differentiate operators in highly competitive markets. Siemens provides carriers with the ability to offer personalized customer applications on existing fixed, mobile and IP networks.

3G/UMTS will be a mobile communications system providing access to a comprehensive set of services, ranging from simple voice and Internet connections to high quality multimedia services with up to 2Mbit/s per call. Intranet, teleworking, home shopping, telelearning, telebanking, information seeking and retrieval, lottery as well as entertainment services will be integrated to offer a universal communications tool for the global citizen at the beginning of the new millennium.





Example Application: Restaurant Finder
 Interactive browsing for location-dependent services can be realized as network-initiated telephony application

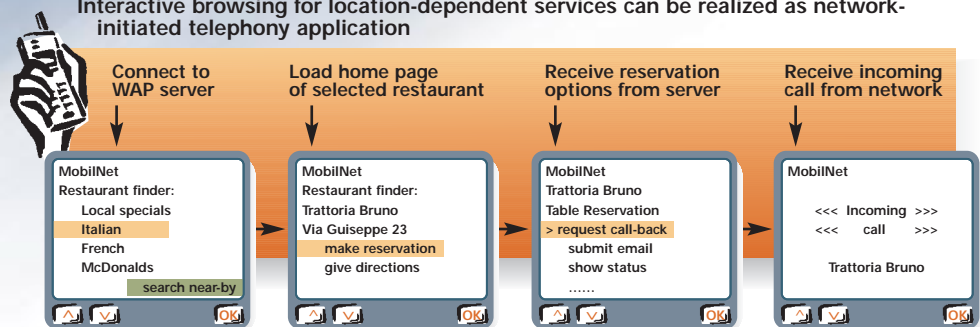

The sound base for UMTS multimedia applications is only the beginning of exploiting mobile data capabilities. User-friendly services which will prove beneficial to subscribers will be crucial to the success of 3G/UMTS.

The All-in-One Switching Platform

Siemens is firmly committed to a 3G evolutionary path where both the GPRS nodes and the GSM MSCs can be upgraded to UMTS core network nodes thus keeping system impact to an absolute minimum. The Siemens UMTS nodes support both 2nd and 3rd generation networks.

The migration path from GSM towards UMTS Network and business evolution



The Future Platform

Right from the beginning, Siemens has offered an outstanding solution for the 3G core node consisting of an integrated GSN/MSC/VLR, which simultaneously supports both packet and circuit switched services – GSM and UMTS on the same switching platform, the UMTS MSC.

All nodes evolve from the combination of the Siemens narrowband and broadband exchanges. The MSC as well as the GPRS nodes are upgradable to UMTS MSC. This unique solution provides connectivity to UMTS and GSM radio networks at the same time. Thus the number of network nodes needed for serving different technologies can be reduced – one platform serves all.



The Siemens switching platform ensures that investments already made in 2G network equipment are optimally protected. Furthermore, a single platform reduces operation and maintenance costs, as well as necessary staff training when migrating to UMTS.

Moving Towards an IP-based UMTS Core Network

The growing demand for IP-based applications serves as a powerful driver for the mobile market. Siemens supports the introduction of IP into the mobile network environment, guaranteeing a smooth evolution towards 3G networks based on IP. Voice-data convergence and the availability of a unique transport network will encourage migration towards an IP-based

core network. We are committed to ensuring seamless interworking and service transparency between 2G mobile networks and 3G networks based on IP.

A unified IP core network provides a variety of new applications which combine voice and data. These include video conferencing, interactive gaming, joint teleworking and application sharing. In this IP environment, standard GSM call control mechanisms evolve towards the H.323 standard (ITU-T standard governing call control for real-time applications transported over IP), which realizes voice and multimedia communications.

UMTS Introduction

UMTS Mass Market

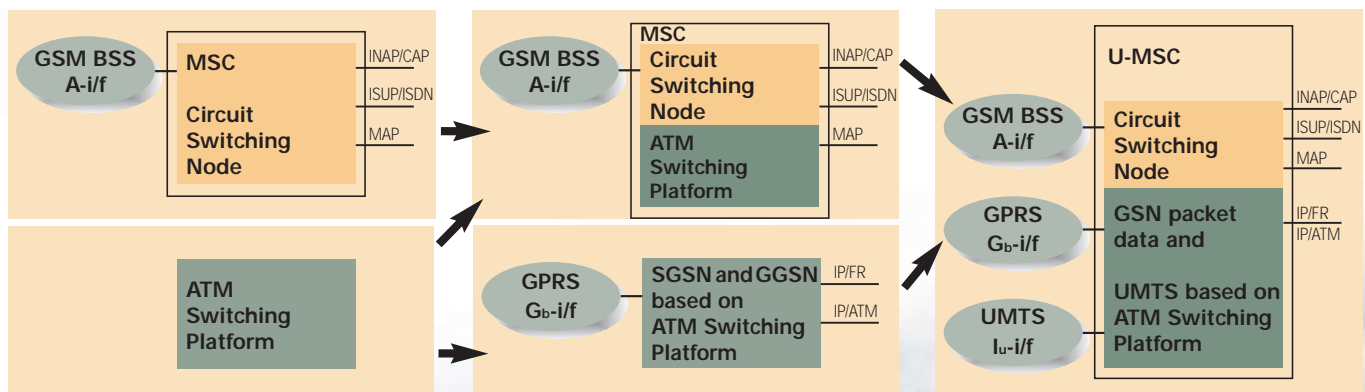
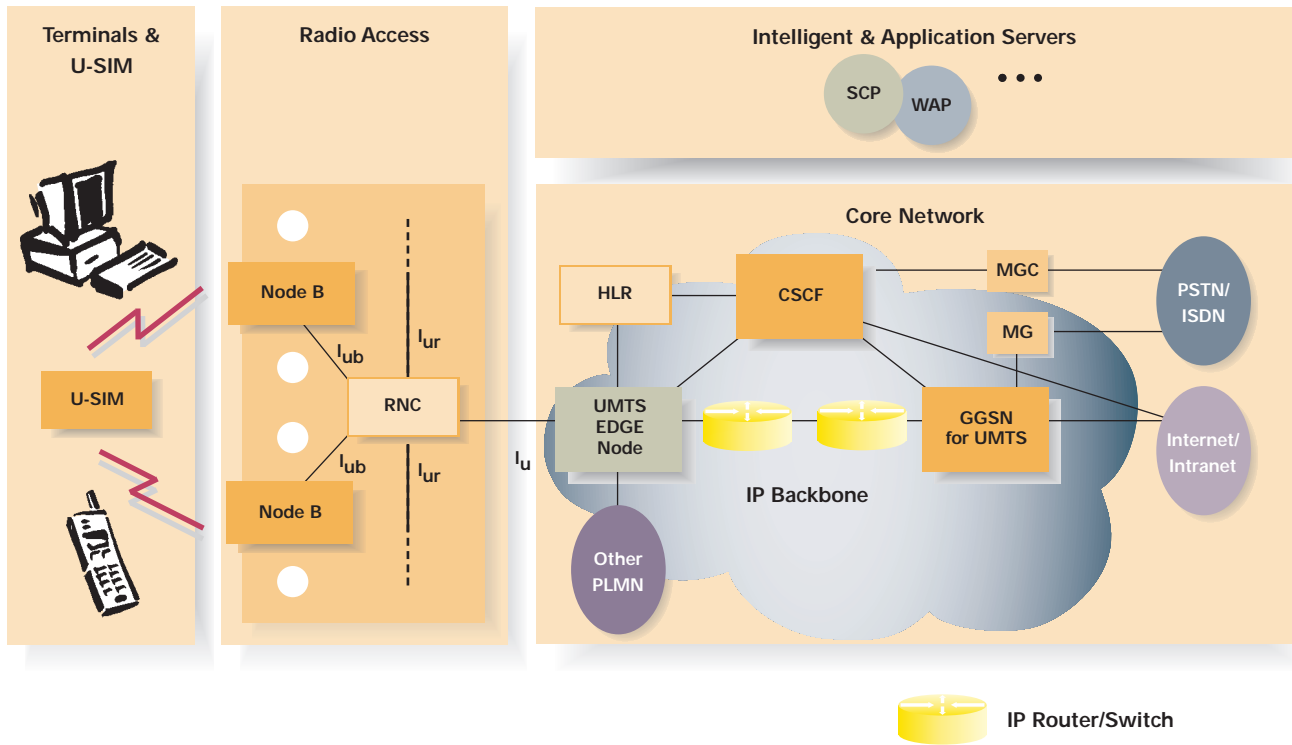

Fig.: All-in-one switching platform evolution

All IP based UMTS core network



Media Gateway Control Concept

Further underpinning our future-proof strategy is the Siemens evolution from the UMTS MSC towards a UMTS EDGE node. Using the media gateway concept, this node provides interworking with an IP-based core network. The media gateway concept ensures interoperability and seamless interworking of existing circuit-switched terminals in an IP core network.

The media gateway controller processes the voice call signaling and performs interworking between H.323 and GSM call control. The media gateway itself is capable of transporting VoIP together with multimedia applications and data transport.

The advanced functions of the media gateway and media gateway controller continue to be supported by the proven 2G/3G switching platforms supplied by Siemens today. A unique upgrade path will ensure that the operator can enter the IP world in a step-by-step approach with full backward compatibility and interworking with 2G mobile networks.

Two Modes

and One Winning Strategy

Beside the improvements concerning data throughput and interworking, 3G will lead to additional spectrum for the operators. With the explosive growth in the market, shortage of capacity is becoming a problem. Capacity enhancement is crucial to an operator's success.

The increased capacity and higher data rates represent significant advantages to network operators and mobile telecom users. The higher data rates ultimately mean that UMTS services can be delivered from residential indoor to the global roaming area. Additionally, the

increase in 3G spectrum efficiency will enable operators to offer value-added services to a greater number of subscribers. In situations where seamlessness is neither adequate or feasible, a close service interworking on network level will be achieved.

Only FDD/TDD dual mode operation supports all these UMTS market requirements.

Both modes target overlapping applications, obtain additional spectrum at enlarged efficiency and are accepted by globally acting operators and vendors.

The two operational modes, FDD and TDD, in parallel provide the end-user with the benefits of both radio access principles in either overlapping or distinct environments.

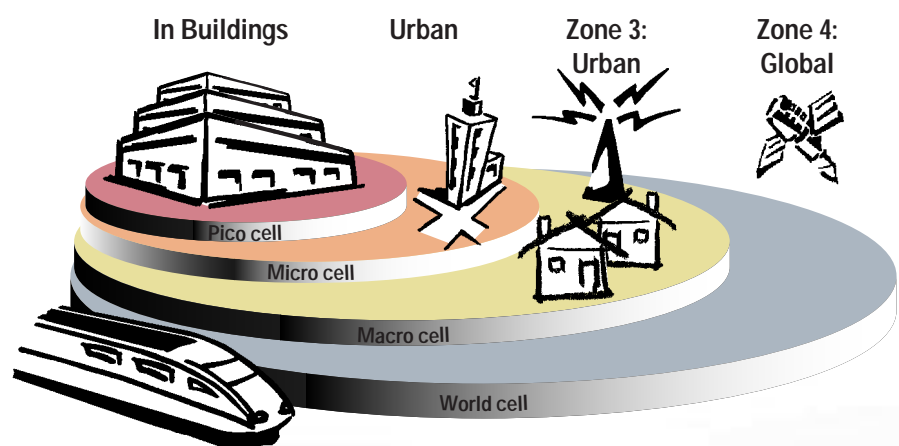

FDD

- Public macro and micro cell environments
- Optimized for symmetrical access
- Up to 384 kb/s

TDD

- Public micro and pico cell environments
- Public WLL
- Unlicensed cordless
- Optimized for symmetrical and Asymmetrical access
- Up to 2 Mb/s

European spectrum allocation for UMTS

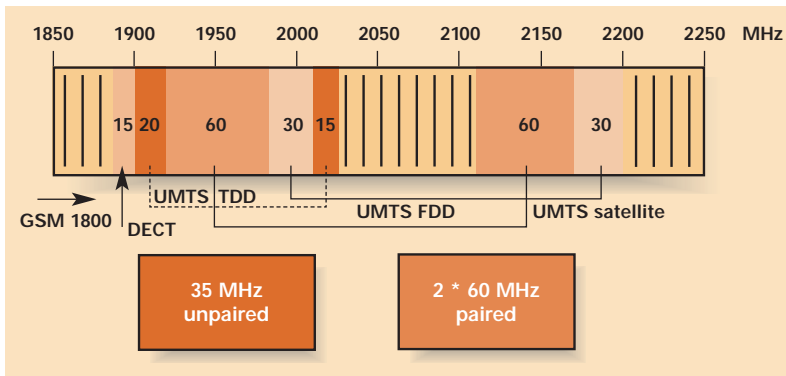

- Free allocation of spectrum gives flexibility to operator & bodies
- 4 Operator scenario recommends (2 x 15 + 5) MHz
- Licensing policy will drive operator's UMTS business

The FDD mode (using W-CDMA) is intended for application in public macro and micro cell environments with data transfer rates with high mobility up to 384 kbps.

FDD is especially suitable for wide-area coverage, even in rural applications. Furthermore, FDD efficiently adapts to varying user data rates by using spreading capabilities. Most of the spectrum allocated for UMTS is paired and assigned for the use of FDD. The UMTS Forum recommends a spectrum of 2 x 15 MHz paired and 5 MHz unpaired for public operators.

The TDD mode (using TD-CDMA) provides distinct advantages in public micro and pico cell environments, for licensed and unlicensed cordless and public wireless local loop. It is ideal for high data rates up to 2 Mbps with low mobility (pedestrian and low speed applications) and explicitly for the increasing asymmetrical traffic demand (such as data transfer and Internet traffic, for example). Pico cells will be introduced for indoor coverage and areas with very high traffic density, e.g. in business areas, airports, shopping malls etc. In addition, use of TDD also in public macro cell environments provides a ready alternative for new entrants focusing their business both on dense urban areas and data services. Pure TDD solutions can be implemented which fit in unpaired spectrum only. TDD is also ideally suited to use in corporate networks due to the high degree of asymmetric traffic.

Terrestrial spectrum requirements
Mobile services – years 2005/2010

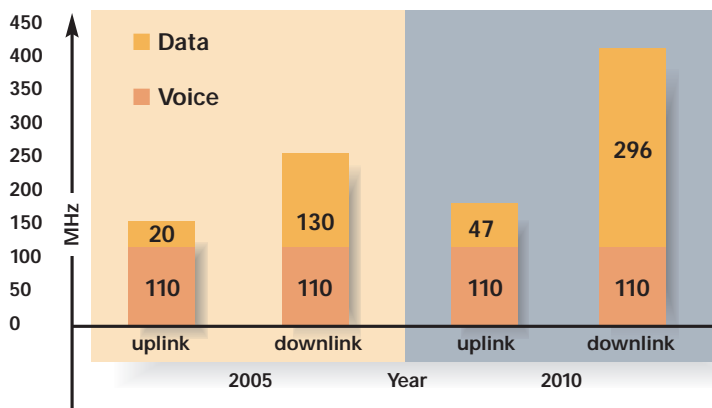

- Due to information download applications, the amount of asymmetry of required spectrum will increase

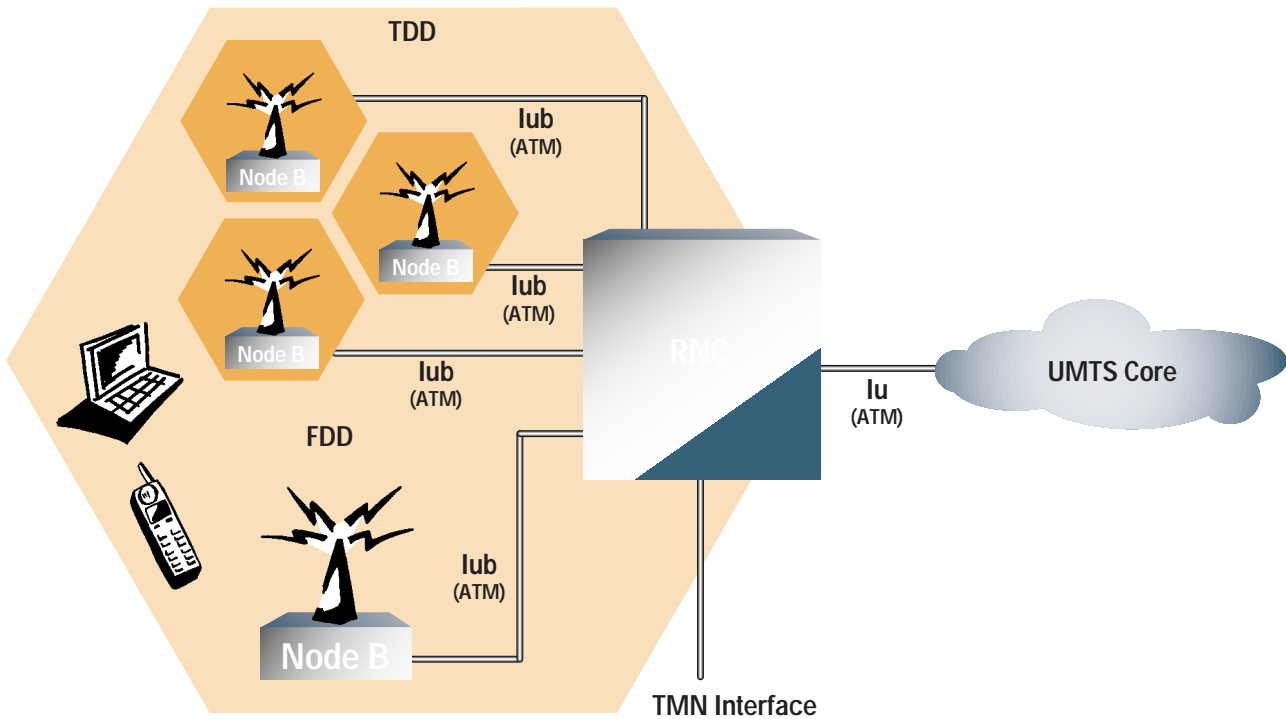

Fig.: Public TDD micro cells in co-existence with FDD macro cells (common RNC)

Technical advantages of TDD in micro and pico cell scenarios:

- Greater spectrum efficiency especially for asymmetric traffic
- Simplified network planning (no cell breathing effect)
- TDD does not require soft handover. In particular, less complexity in network controlling suggests IP solutions e.g. for corporate use.
- TDD supports data rates up to 2Mbit/s with low mobility (pedestrian)

As every operator knows spectrum is a scarce resource. UMTS alleviates this problem through the deployment of the two modes which enhance spectrum efficiency. The GSM Association believes that by 2005, the date for mass market introduction of UMTS, asymmetry between upstream (UL) and downstream (DL) will have reached a factor of 1:5. The main driver will be the use of the mobile Internet. The TDD mode utilizes spectrum very efficiently due to the fact that variable amounts of spectrum can be allocated for uplink and downlink traffic.

Siemens fully supports the UMTS UTRAN concept with these two radio access modes. The solution offered is cost efficient and supports the easy introduction of UMTS. Operators' investments are kept to a minimum over the evolution of GSM to the 3rd generation, and full support is provided for IP technology. The Siemens solution supports the UTRAN solution with FDD and TDD being connected to the same RNC.

Go 3G with Siemens

Tomorrow's market needs are determined by mass mobile market, IT & T convergence and personalized communication.

3G/UMTS will be based on a highly-efficient radio-frequency access linked to the core network. Siemens provides customized solutions to easily upgrade from existing 2nd generation to 3rd generation nodes.

The 3G/UMTS air interface will deliver services ranging from high volume narrowband for the mass market to high value broadband for high-end users. These services will be delivered seamlessly from residential indoor to the global area via the two modes (TDD and FDD) in line with the user's environment.

Siemens' solutions provide a smooth evolution path from 2G to 3G. Operators can introduce 3G according to market developments and user requirements. Siemens protects the operator's investment as the GSM network is used as the springboard to 3G revenues.

Siemens' approach to the evolution of mobile communications and its development of superior applications environments clearly show how we can help move carriers into the next generation of mobile technology.

Abbreviations

2G	Second Generation	ISUP	ISDN User Part
3G	Third Generation	MAP	Mobile Application Part
ATM	Asynchronous Transfer Mode	MG	Media Gateway
BSS	Base Station Subsystem	MGC	Media Gateway Controller
CAP	CAMEL Application Part	MSC	Mobile Switching Center
CDMA	Code Division Multiple Access	PLMN	Public Land Mobile Network
CSCF	Call State Control Function	PSTN	Public Switched Telephone Network
EDGE	Enhanced Data Rates for GSM Evolution	RNC	Radio Network Controller
FDD	Frequency Division Duplex	RX	Number of Receive Slots
FR	Frame Relay	SCP	Service Control Point
GGSN	Gateway GPRS Support Node	SGSN	Serving GPRS Support Node
GPRS	General Packet Radio Service	TD-CDMA	Time Division CDMA
GSM	Global System for Mobile Communications	TDD	Time Division Duplex
GSN	GPRS Support Node	TMN	Telecommunication Management Network
HLR	Home Location Register	TX	Number of Transceive Slots
HSCSD	High Speed Circuit Switched Data	U-MSC	UMTS Mobile Switching Center
INAP	Intelligent Network Application Protocol	UMTS	Universal Mobile Telecommunications System
IP	Internet Protocol	U-SIM	UMTS Subscriber Identity Module
ISDN	Integrated Services Digital Network	UTRA	Universal Terrestrial Radio Access
ITU-T	International Telecommunication Union-Section Telecommunication Standardization	UTRAN	Universal Terrestrial Radio Access Network
		VLR	Visitor Location Register
		W-CDMA	Wideband CDMA
		WLL	Wireless Local Loop



Contact us!

Visit our website at
<http://www.siemens.com/ic/networks/ca>