

A Drift-Free VFO

Build this clean, quiet, stable VFO.

The last decade has seen a considerable improvement in the area of receiver IMD distortion (IMD) characteristics, which has enhanced the ability of amateur receivers to handle strong signals. Conversely, the ability of receivers to receive weak signals in the presence of strong unwanted signals is limited either by the receiver IMD capabilities or local-oscillator (LO) phase noise. The phase noise of a properly designed, free-running LC VFO need not limit dynamic range.

Many VFO designs have appeared in the Amateur Radio literature, and the quest for

a low-drift VFO hasn't ceased. If the frequency-stability requirements are stringent, the thermal-drift compensation can be very tedious. Wes Hayward's recent *QST* article¹ devoted to VFO drift compensation is an excellent example of this difficult pursuit.

For many designers, the quest for stability ended when low-cost frequency synthesizers appeared. Unfortunately, synthesizers come with problems—notably phase-noise problems and spurious responses. Building a low-phase-noise synthesizer is a serious undertaking—it requires considerable technical skill and possibly prohibitive cost and circuit complexity.

This article demonstrates that an LC VFO still offers excellent spectral purity, low

cost, ease of construction and component availability. It shows that it is possible to combine in a VFO both very low phase noise and exceptionally good long-term stability.

Design Criteria

To avoid degradation of the receiver's front end, several requirements should be imposed on the phase noise level of the VFO. An excessively high level of close-in phase noise (within the bandwidth of the SSB signal) may reduce the receiver's ability to separate closely spaced signals. As an example, a 14-pole crystal filter described in Note 2 provides adjacent-signal rejection of 103 dB at a 2-kHz offset. This requires the use of a VFO with -139 dBc/Hz

¹Notes appear on page 36.

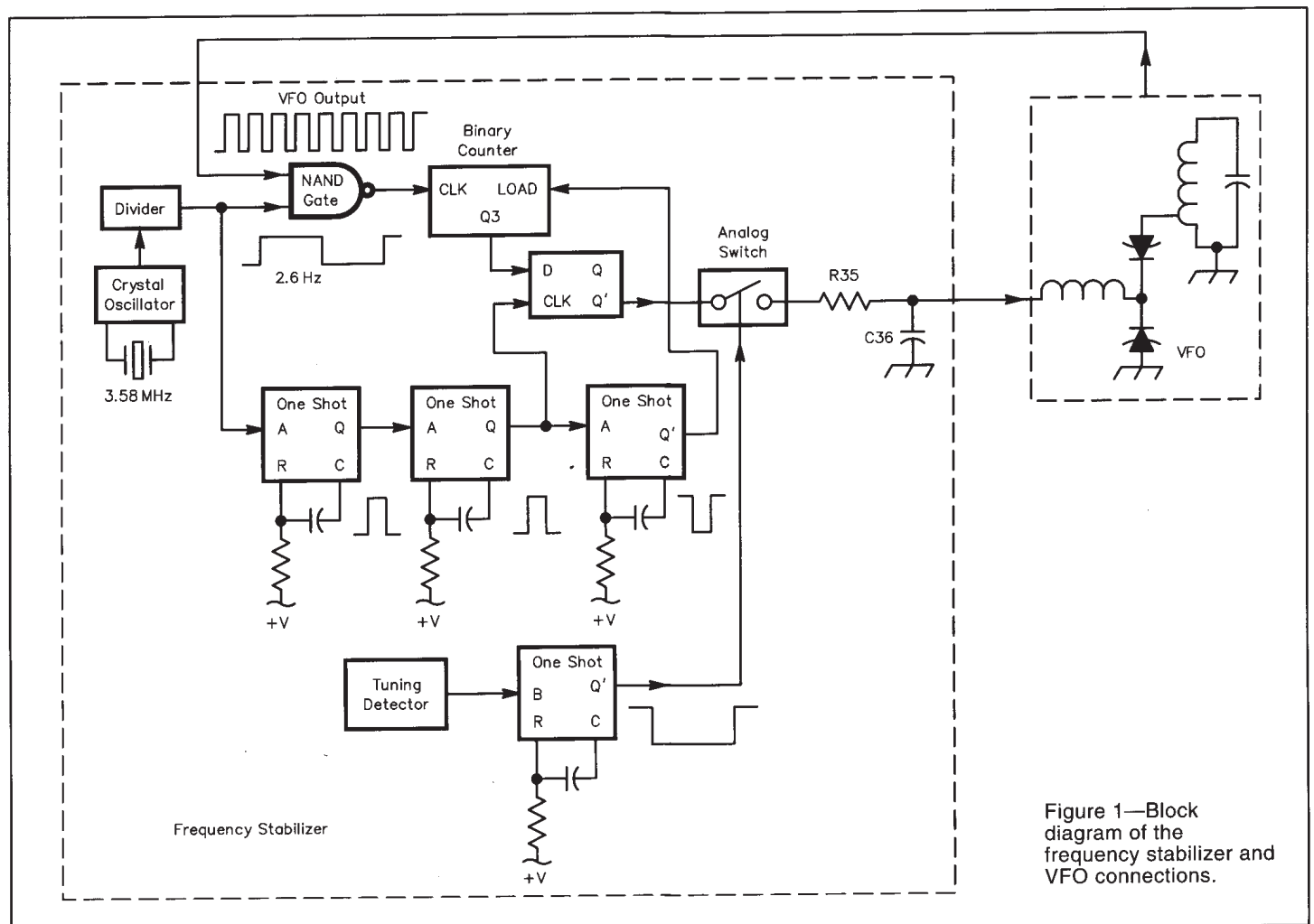

Figure 1—Block diagram of the frequency stabilizer and VFO connections.

phase noise at a 2-kHz offset.

$$P_n = P - 10 \log(BW) = -103 - 10 \log(4000) = -139 \text{ dBc/Hz}$$

where

P_n = VFO phase-noise spectral density, in decibels relative to the carrier output power, in a 1-Hz bandwidth (dBc/Hz)

P = VFO power level (dBc) in a given bandwidth (BW)

BW = test bandwidth, in Hertz

In addition, excessive close-in phase noise may lead to reciprocal mixing, where

the noise sidebands of a VFO mix with strong off-channel signals to produce unwanted IF signals.

Excessive far-out phase noise may degrade the receiver dynamic range. In a properly designed receiver, the phase-noise-governed dynamic range (PNDR) should be equal to or better than the spurious-free dynamic range (SFDR). We can calculate the PNDR:³

$$\text{PNDR} = -P_n - 10 \log(BW)$$

Assuming the PNDR equals the SFDR

at 112 dB in a 2.5-kHz IF noise bandwidth, the required far-out phase noise level is -146 dBc/Hz:

$$P_n = -\text{SFDR} - 10 \log(BW) = -112 - 34 = -146 \text{ dBc/Hz}$$

Another form of VFO instability—frequency drift—has always been a nuisance and a great concern to the amateur community. The objective of this project was to keep the long-term frequency drift (seconds, minutes, hours) under 20 Hz. This includes thermal drift from both in-

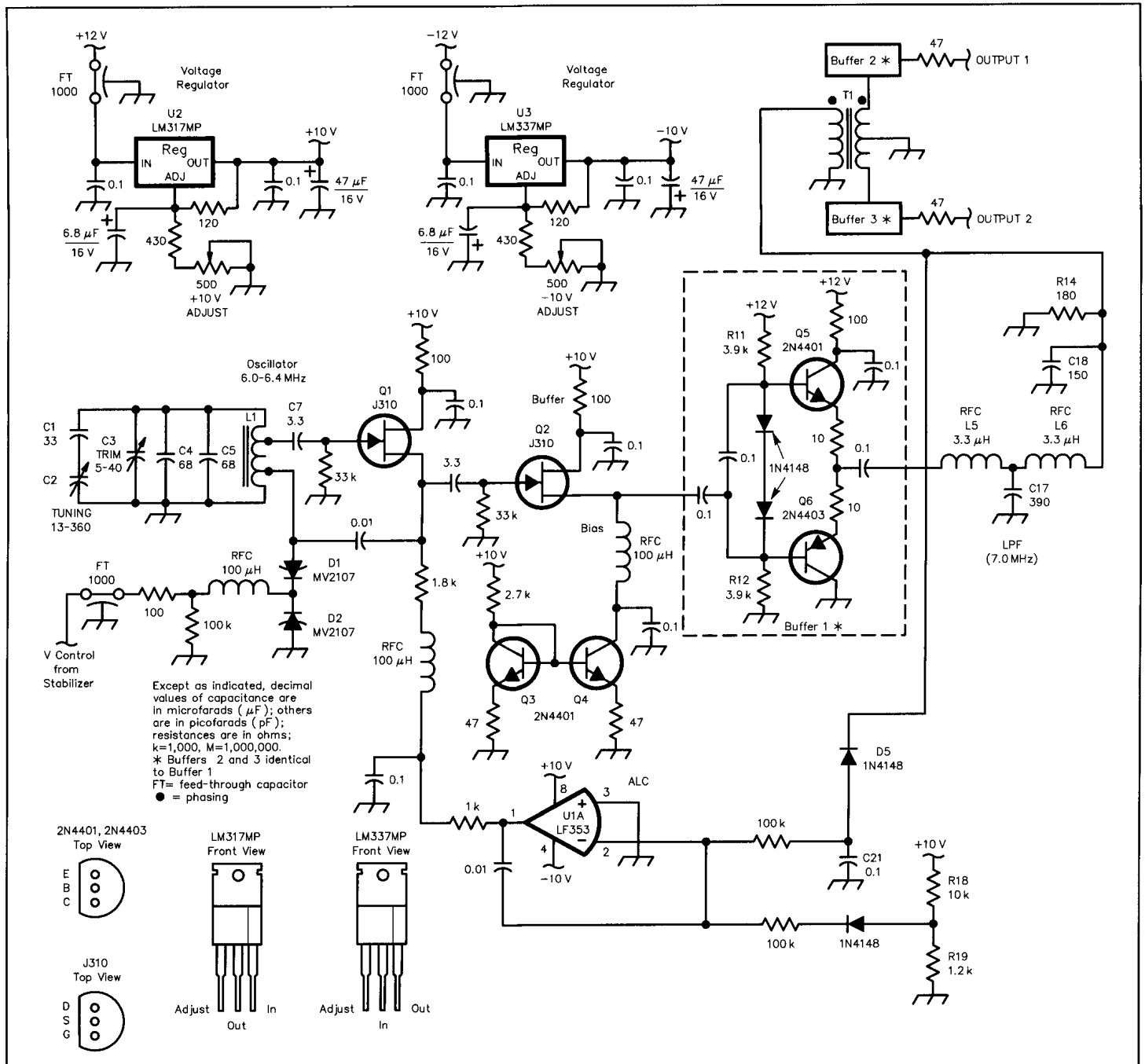

Figure 2—VFO schematic. Buffers 2 and 3 are identical to Buffer 1. Most of the parts are available from Mouser Electronics, Digi-Key Corporation or Allied Electronics. The cores for L1 and T1 are from Amidon Associates.⁷ Use 1/4-W, 5%-tolerance carbon-composition or film resistors and ceramic, 20%-tolerance capacitors unless otherwise indicated. RF chokes or encapsulated inductors may be used for those labeled "RFC."

Q1, Q2—J310, N-channel JFET (Allied)
 D1, D2—MV2107 or ECG/NTE613 tuning diode (Varicap, Allied)
 L1—29 turns of #18 AWG enameled

copper wire on a T-80-6 iron-powder toroidal core tapped at 4 turns and 20 turns from the cold end (Amidon)
 T1—#32 AWG enameled copper wire on a BN-43-2402 two-hole ferrite balun core

(Amidon) primary: 5 turns; secondary: 16 turns, center tapped
 Vector part #8007 circuit board (Digi-Key)
 Vector part #T44 terminals (Digi-Key)

ternal heating and environmental changes.

Block Diagram

The block diagram of Figure 1 shows the LC VFO and the frequency stabilizer. The stabilizer monitors the VFO frequency and forms an error signal that is applied to the VFO to compensate for frequency drift. This technique, which is capable of stabilizing a VFO to within a few hertz, was devised by Klaas Spaargaren, PAØKSB, and first described in *RadComm* magazine in 1973.⁴ My project builds upon Spaargaren's idea and presents a few refinements.

The stabilizer converts a free-running VFO into an oscillator that can be tuned in the usual fashion, but then locks to the nearest of a series of small frequency steps. Unlike traditional PLL frequency synthesizers, the stabilizer has no effect on the phase-noise performance of the VFO; it only compensates for thermal drift.

The timing signal (2.6 Hz) is derived from a crystal oscillator via a frequency divider. The timing signal drives a **NAND** gate to provide a crystal-controlled time window, during which the binary counter counts the VFO output. When the gate closes, the final digit of the count remains in the counter. For counts 0 to 3, the Q3 output of the counter is a logic 0; for counts of 4 to 7, a logic 1.

The result is stored in a D flip-flop memory cell: When the 2.6-Hz timing signal goes low, the first of three one-shots triggers. The second follows and clocks the binary counter Q3 output into the memory cell. The negative-going pulse from the third resets the counter for the next counting sequence.

The output of the memory cell is applied to an RC integrating circuit with a time constant of several minutes. This slowly changing dc voltage controls the VFO frequency via a couple of Varicaps connected to a tap on the VFO coil.

If the counter output is 0, the memory-cell output is 1, which charges C and increases the VFO frequency. A counter output of 1 discharges C and decreases the VFO frequency. The stabilizer constantly searches for equilibrium, so the VFO frequency slowly swings a few hertz around the lock frequency. The circuit limits the frequency swing to a maximum of ± 2 Hz, typically ± 1 Hz.

A difficulty arises when the operator changes frequency because the control voltage is disturbed. If the memory-cell output connects directly to the RC integrator, the frequency correction that occurs immediately after tuning results in a frequency hop. To overcome this problem, an analog switch disconnects the integrator from the memory during tuning. The tuning detector—an infrared interrupter switch and a one-shot—controls the analog switch.

Circuit Description

VFO

The VFO is a tapped-coil Hartley oscil-

lator that is optimized for low phase noise (see Figure 2). Ulrich Rohde compiled a set of design rules intended to minimize the phase noise in oscillators.⁵ The guidelines implemented in this design are:

- Maximize the unloaded Q of the resonator
- Maximize the RF voltage across the resonator
 - Avoid device saturation at all costs
 - Choose an active device with a low noise figure
 - Minimize phase perturbation by using a high-impedance device (FET)
 - Don't use a gate-clamping diode to limit voltage swing

The tank coil, L1, has an iron-powder toroidal core; coil Q exceeds 300. C1, C4, C5 and C7 are NP0 (C0G) ceramic capacitors (5% or 10% tolerance). C2 is the main tuning capacitor, and C3 is a small ceramic trimmer capacitor.

The VFO frequency range is set from 6.0 MHz to 6.4 MHz (to accommodate a 20-meter receiver with an 8-MHz IF). The loaded Q of the resonator is kept high by using a tapped coil and loose coupling to the gate of the FET through C7 (more than 8 k Ω at 6 MHz). The RF voltage swing across the resonator exceeds 50 V, P-P. Varicaps D1 and D2, which compensate for thermal drift, are connected across the coil's lower tap (less than 14% of the total turns) and have a negligible effect on overall phase-noise. J310 is the TO-92 version of U310—a very low-noise FET in HF applications.

An ALC loop limits the voltage swing. The signal is sampled at the primary of T1, rectified by the D5-C21 network and fed to the inverting input of an integrator, U1A, where it is compared against the reference voltage at the junction of R18 and R19. The dc voltage at the integrator output sets Q1's drain current so that the signal swing at T1's primary is always 2.5 V, P-P. The ALC loop also makes VFO performance independent of Q1's pinch-off voltage. The signal at Q1's source is a 6.5-V, P-P, sinusoid with almost no distortion.

Q2 is a high-impedance buffer that is loosely coupled to Q1. Q2's drain current is set to 3.4 mA (by the constant-current source, Q3-Q4) regardless of Q2's pinch-off voltage.

Buffer 1 is a push-pull stage biased into slight conduction by resistors R11 and R12. It has excellent linearity and a very low output impedance, which is required to drive an LC filter. The filter (L5, L6, C17, C18 and R14) is a four-pole, 0.1-dB Chebyshev low-pass filter with a ripple frequency of 7 MHz. All harmonics at the VFO output are at least 45 dB below the fundamental.

T1 provides the two complementary outputs required for a commutation mixer and raises the voltage swing at the VFO output.

Buffers 2 and 3 are electrically identical to buffer 1. They further decouple the VFO

from its load and serve as low-distortion 50- Ω drivers. The signal level at each output is 4 V, P-P, when driving a high-impedance load (eg, a CMOS gate), +10 dBm when driving a 50- Ω load.

Frequency Stabilizer

NAND gates U4A and B (see Figure 3) comprise a Pierce crystal oscillator. The timing signal (2.6 Hz) appears at the output of the frequency divider (U5, U6, U7 and U8A). The exact frequency of the crystal and the timing signal is unimportant, but the stabilizer has been optimized for 2.3 to 2.7 Hz.

There are two requirements for the crystal oscillator: No harmonics should fall in the IF passband, and the crystal should have a low temperature coefficient. Crystal-oscillator thermal drift should not exceed 10 Hz within the temperature operating range. Crystals in HC-33 cases with frequencies between 2.0 and 3.58 MHz worked best for me. The frequency divider is sufficiently flexible to provide the desired timing-signal frequency.

U4C, biased into a linear range, converts the sinusoidal signal from one of the two VFO outputs into a square wave. U4D gates the VFO signal bursts into the clock input of the binary counter, U9. At the end of every burst, the final digit is held by the counter.

The falling edge of the timing signal triggers U10A, the first of three cascaded one-shots. The pulse at the output of U10B clocks the data from the counter into U8B. The pulse at the output of U11A resets U9.

If the number of pulses in each successive burst is equal (no VFO drift), U9 constantly counts the same number, and the output of U8B never changes. In practice, however, U8B constantly toggles between two states. The integrating circuit, R35-C36 (time constant = 6.5 minutes), converts the toggling into a slowly changing voltage. Varicaps D1 and D2 transform a few millivolts of change into ± 1 or 2 Hz change of VFO frequency.

U13A, a high-input-impedance buffer, prevents the discharge of C36. U13B, a noninverting amplifier with a gain of 1.5, ensures compliance between the control-voltage range and the capacitance-per-volt ratio of the Varicaps (1 to 6 V for best performance). Network R36, R37, C37 and D7 establishes the initial dc voltage applied to the varicaps; the value is set by the C37-C36 voltage divider.

An infrared interrupter switch, U14, serves as sensor in the tuning-detector circuit. The slotted interrupter detects the movements of a serrated disc (see Figure 4) on the VFO reduction-drive shaft. U15A and B, a two-level limit comparator, converts the signal at its input into pulses. U16A produces trigger pulses for the one-shot, U11B, by detecting both leading and falling edges of the signal at its input. U11B is retriggerable—its Q' output stays low during manual tuning and for 3.6 seconds after tuning stops. Analog switch U12A disconnects

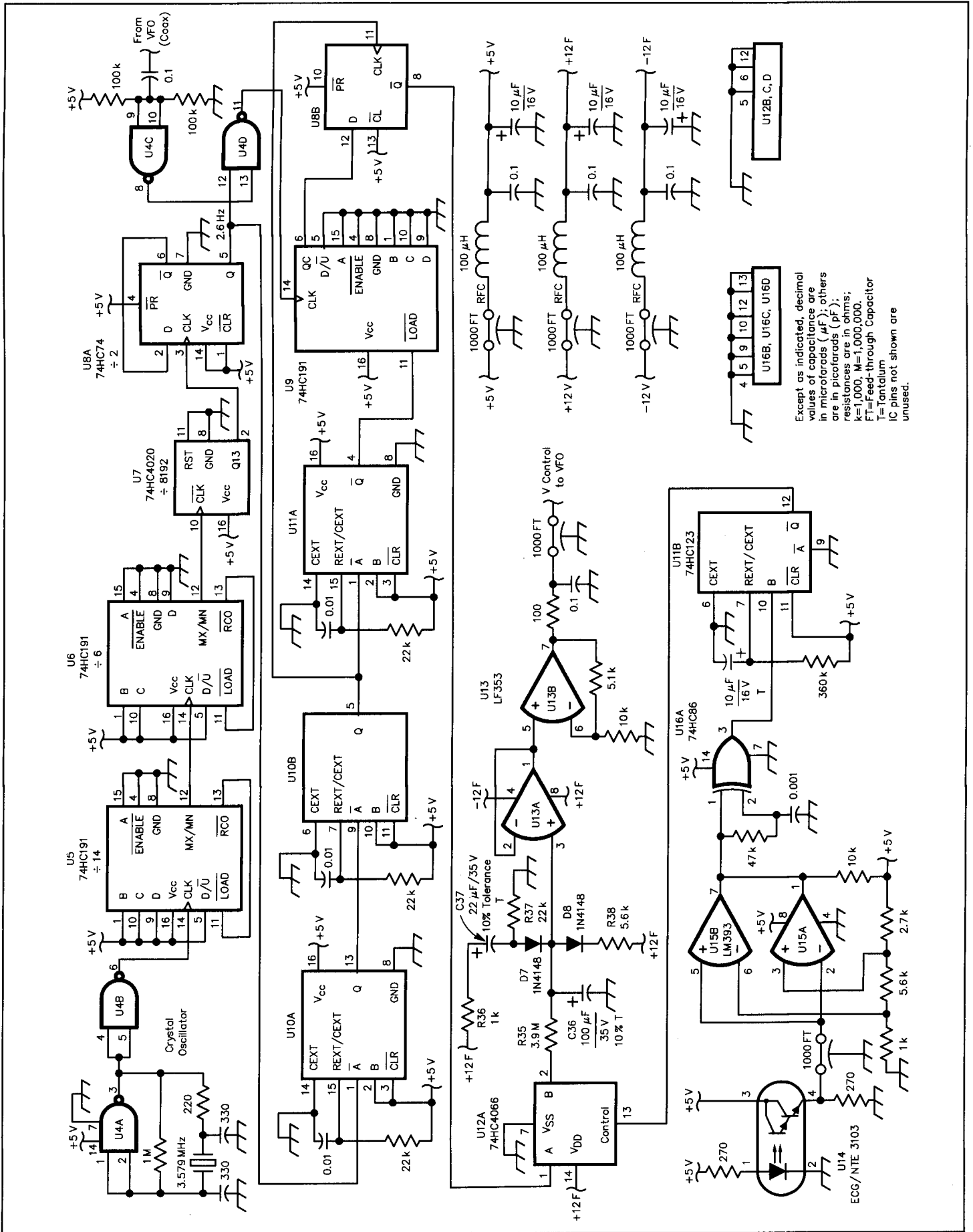

Figure 3—Stabilizer schematic. Use 1/4-W, 5%-tolerance carbon-composition or film resistors and ceramic, 20%-tolerance capacitors unless otherwise indicated.

U4—74HC00 Quad NAND gate
 U5, U6, U9—74HC191 presettable 4-bit binary counter

U7—74HC4020 14-bit binary ripple counter
 U8—74HC74 dual D flip-flop
 U10, U11—Dual 74HC123 one-shot

U12—4066 quad analog switch
 U14—ECG/NTE3103 optical interrupter (Darlington output, Allied, see Note 7)

Except as indicated, decimal values of capacitance are in microfarads (μF); others are in picofarads (pf); resistances are in ohms; k=1,000, M=1,000,000. FT=Feed-through Capacitor T=Tantalum IC pins not shown are unused.